



PERMAS is a general purpose software system to perform complex calculations in engineering using the Finite Element Method (FEM), and to optimize the analyzed structures and models.

VisPER (Visual PERMAS) is the fully compatible pre- and post-processor for PERMAS.

PERMAS is an integrated software for thermo-mechanics, vibro-acoustics, and optimal design.

INTES is a privately held and independent enterprise for Finite Element Technology (FE Technology) with offices in Stuttgart, Paris and Tokyo.

For all of its customers, INTES is a competent partner in all aspects of FE Technology. Above all, satisfaction of the customers with all the software and services is of prime importance to the company.

INTES offers the FE software PERMAS (including VisPER as graphical user interface), related software developments, training courses, consulting and simulation services.

The expertise in FE Technology is based on long-term numerical and graphical software development of FE methods and on many industrial applications of these methods.

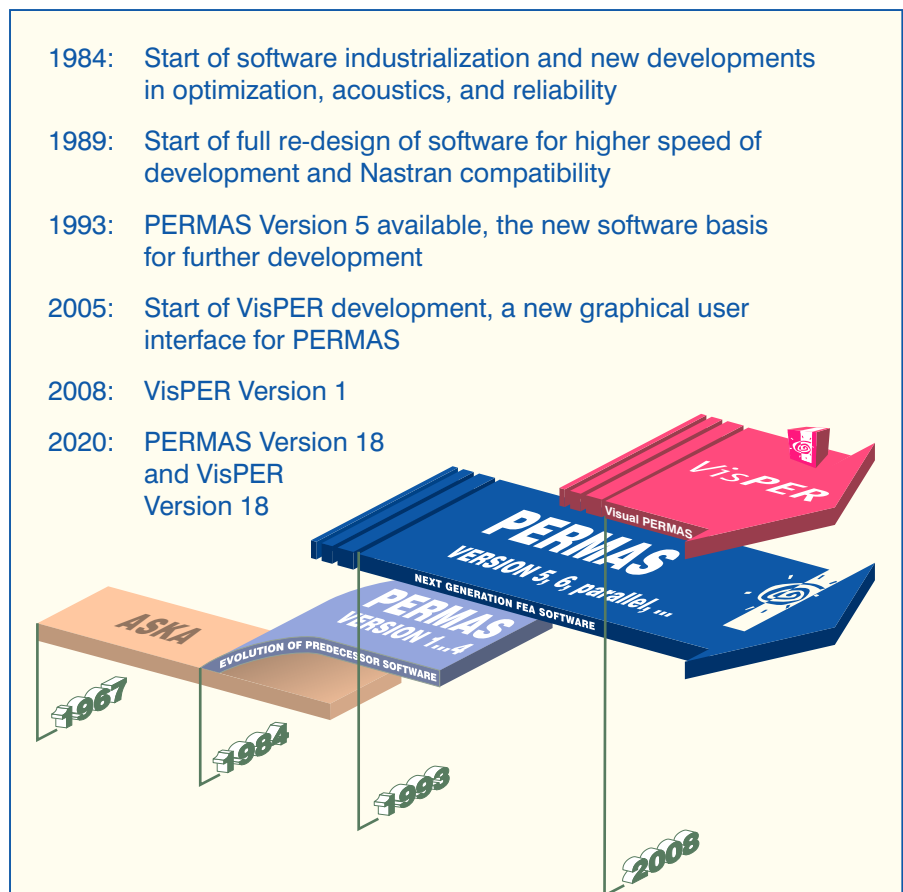

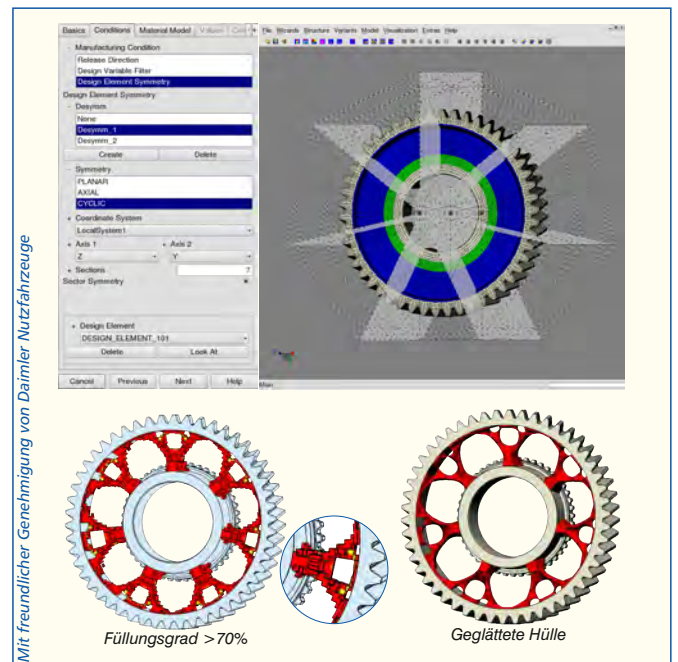
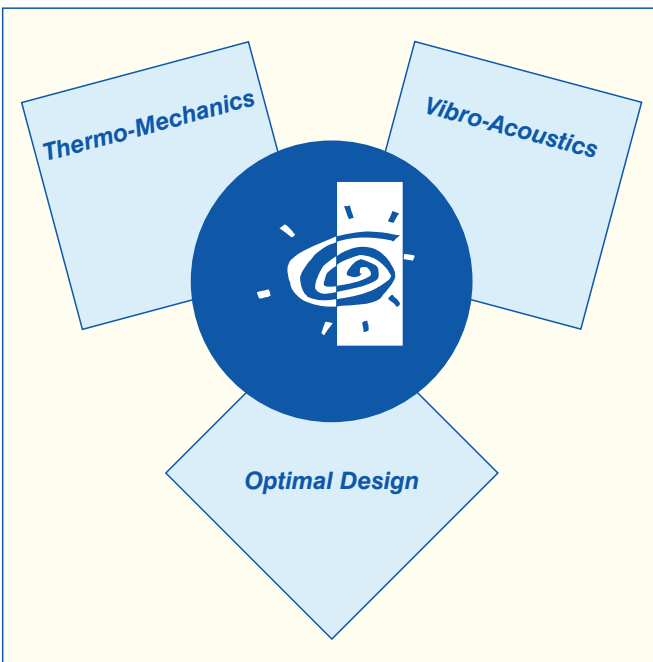

PERMAS is making realistic simulations practical.

PERMAS provides extremely fast and accurate solutions for realistic simulations of large models and complex situations in time.

PERMAS effectively supports performance based design decisions without the need to sacrifice accuracy.

Customers get high value out of PERMAS:

- To reach improved understanding of product performance and better product designs.
- More design iterations for more accurate models for the same simulation costs.
- Better product designs through effective and rapid optimization of complex situations.
- Reduced effort, cost and time to achieve reliable performance driven designs.
- Reduced risk and uncertainty through robust design and reliability analysis.

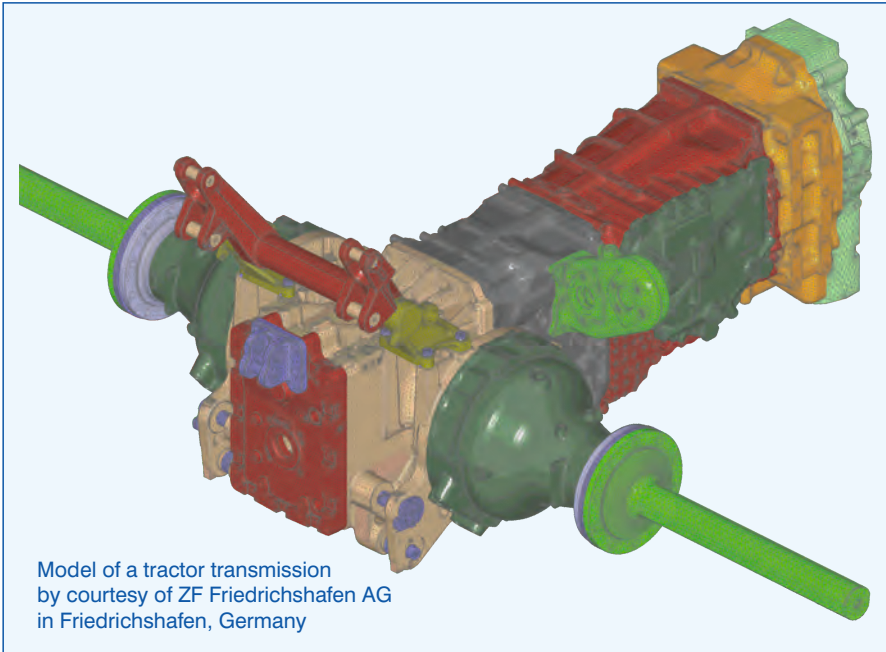

Model of a tractor transmission  
by courtesy of ZF Friedrichshafen AG  
in Friedrichshafen, Germany

This group of modules comprises functionalities for the determination of temperature fields, contact analysis, and linear and nonlinear static analysis as well as buckling.

The analysis of linear and nonlinear, steady-state and transient **heat transfer analysis** is supported. Heat conductivity, heat capacity, and heat convection with radiation can be used accordingly. Previously calculated temperature fields can be directly used in subsequent static analysis.

The linear **buckling** analysis is a classical method to study shell and beam structures. It can be used also after a nonlinear static analysis in order to detect additional bifurcation points.

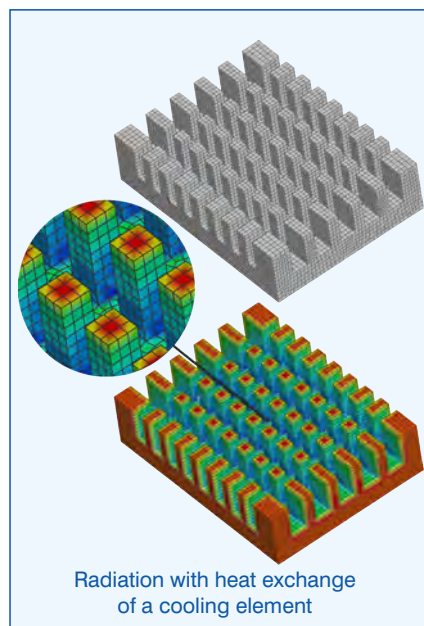

Radiation with heat exchange  
of a cooling element

**Contact** is a nonlinear boundary condition, which can be coupled with other linear conditions as well as with nonlinearities. At the same time, the contact can be calculated between different bodies, between a body and ground, but also when self contact occurs.

The contact analysis can be performed with or without friction, where isotropic or orthotropic sticking and sliding friction is applied following Coulomb's law of friction.

The CLF (Condensed Lagrange Flexibility) method provides high performance contact analysis. The integrated ContactAnalysisMultiGrid (CAMG) solver reduces drastically run times for large contact models (> 10,000 contacts).

The contact analysis is most efficient, when no friction has to be taken into account.

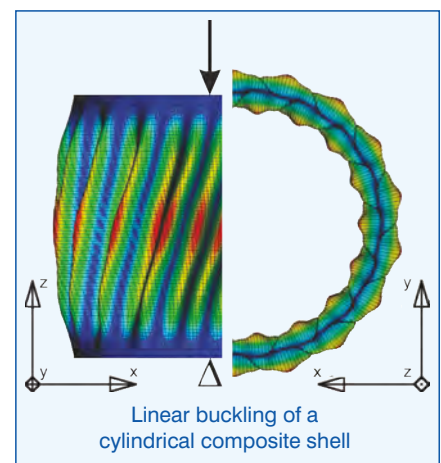

Linear buckling of a  
cylindrical composite shell



Contact can be calculated between compatibly and incompatibly meshed parts. In both cases, the resulting contact pressure is available.

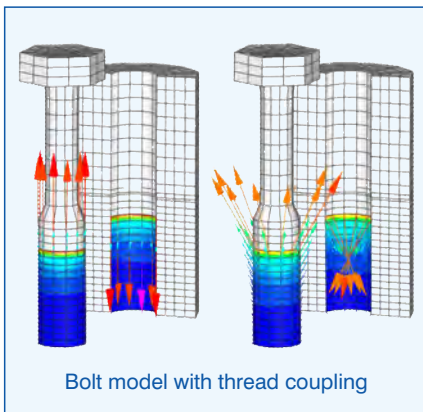

**Bolt pretension** is also made by contact. The coupling of screw and mating thread takes place at the thread area, while the bolt and the bolt hole remain perfectly cylindrical. By doing so, the radial widening of the bolt hole and the twist of the bolt can be modeled by a flank angle and the pitch of the thread without modeling the thread itself.

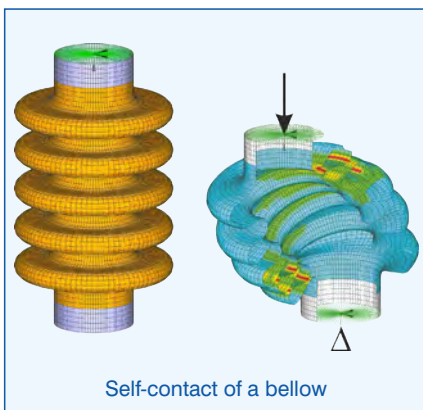

By **updating the contact geometry**, large sliding displacements can be calculated. Together with geometrical nonlinear effects, large rotations are carried out.

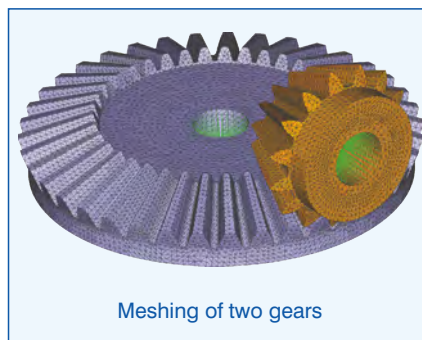

**Nonlinear gaskets** are modeled by special gasket elements, which are fully handled by contact analysis.

Purely **force-guided contacts** are also possible with larger initial gap widths.

An **obtained contact status** can be re-used in a subsequent variant analysis. This has the potential to reduce the run time of the variant analysis significantly.

To perform a **subsequent dynamic or heat transfer analysis**, the achieved contact status can be frozen, where a pressure dependent coupling is supported.

**Nonlinear material behaviour** can use different constitutive models: nonlinear elastic material, elastic-plastic material (von Mises, Tresca, Drucker-Prager, Mohr-Coulomb, cast iron), simple visco-plastic material, creep. At the same time, the material can be temperature-dependent. In case of plasticity isotropic or kinematic hardening can be taken into account (the latter also as nonlinear kinematic hardening). A user-defined material is possible.

Beside isotropic plasticity models, transverse isotropic plasticity for short fiber reinforced plastics is also supported.

For large models and local nonlinear effects, substructuring and submodeling can be used in nonlinear analysis.

**Geometric nonlinearities** can be combined with other linear or nonlinear effects. Also nonlinear buckling of shell structures is supported with linear or nonlinear material behaviour. It can be amended by linear buckling in each load step in order to detect bifurcations.

**Large strain** analysis for hyperelastic materials is supported, where the same element types are used as for other linear or nonlinear analyses.

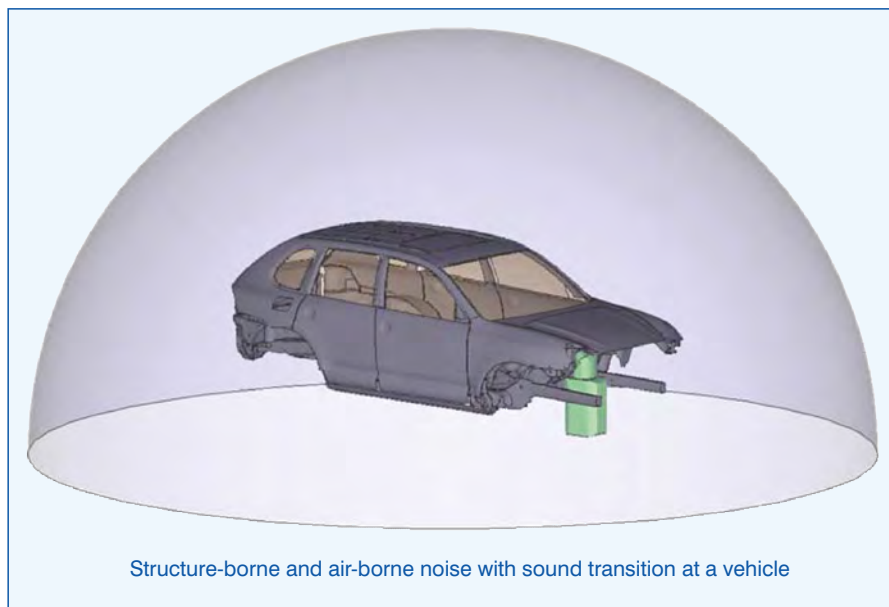

Structure-borne and air-borne noise with sound transition at a vehicle

This group of modules comprises functionalities in modal space with real and complex eigenvalue analyses, dynamic condensation, and response analysis in frequency and time domain (also steady-state) for **structural dynamics**. Additionally, spectral and random response analysis are available. Direct solutions for response analysis in frequency and time domain are available, too.

For both a **Fluid** only and the coupled **Fluid-Structure-Acoustics**, real eigenvalue analysis, dynamic condensation, and response analysis in frequency and time domain as well as random response are supported in modal space. A direct solution for the response analysis in frequency domain is also available.

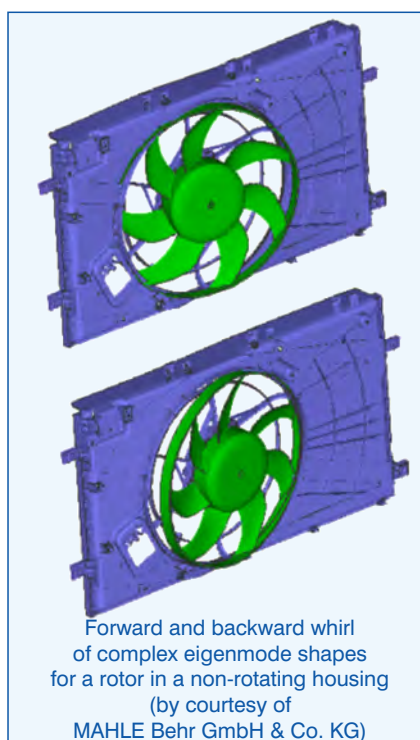

Forward and backward whirl of complex eigenmode shapes for a rotor in a non-rotating housing (by courtesy of MAHLE Behr GmbH & Co. KG)

The modeling of a fluid is using volume elements and the connection to the structure is using coupling elements. For the boundaries of surrounding fluids, radiation boundary condition elements and semi-infinite elements are available.

In a real **eigenvalue analysis** of a structure the elastic stiffness can be extended by geometric stiffness and pressure stiffness, if needed. In rotor dynamics, centrifugal stiffness or convective stiffness can be taken into account as the case may be calculated in a co-rotating or inertial reference system.

The real eigenvalue analysis in coupled fluid-structure acoustics results in eigenmodes, which consist of displacements for the structure and a corresponding pressure field for the fluid.

For very large models with a high number of modes to be calculated, a special eigenvalue solver using the **MLDR method** (Multi-Level Dynamic Reduction) provides an extraordinary efficient procedure.

The **complex eigenvalue analysis** is based on real eigenvalues and mode shapes. For rotating structures, a Campbell diagram for an arbitrary number of rotating speeds can be generated in one single run.



Many options for the modeling of **damping** are available like material damping, proportional damping, viscous damping elements, modal viscous damping, modal structural damping, and direct input of damping matrices (also in modal space).

In frequency domain, structural damping can be described as a function of frequency. A frequency-dependent viscous damping is supported by a special element.

The modeling of **active damping** is possible using control elements, which combine dynamic vibrations (detected at a sensor) with a driving force (applied at the actuator) using classical linear or nonlinear control parameters.

For complex position and velocity control (like for machine tools) additional **control elements** are on hand.

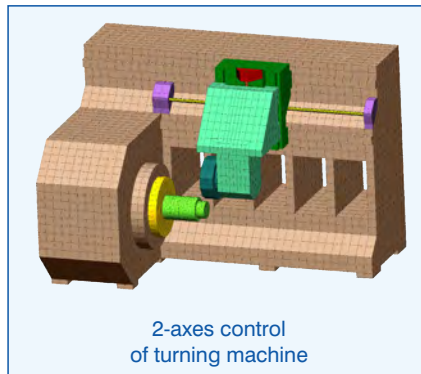

In case of coupled **fluid-structure acoustics**, a structure with enclosed fluid can be condensed in a way that no pressure degrees of freedom are present in the condensed system (so-called dry condensation).

For **dynamic condensation**, an extended Craig-Bampton method can be applied (i.e. MBCB Mixed Boundary Craig-Bampton), which allows the use of vibration modes under different boundary conditions (also free-free).

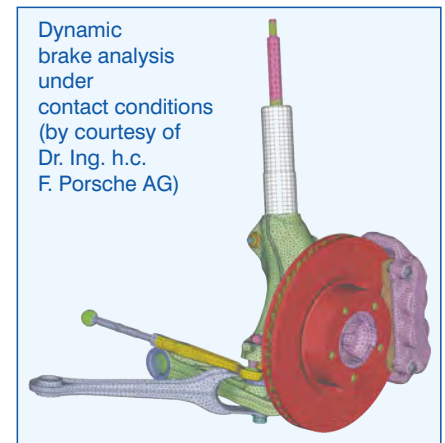

In **dynamic brake analysis** the contact status between brake pad and disc can be frozen for a subsequent real and complex eigenvalue analysis to identify instabilities indicating brake squeal. An additional parameter study using the integrated sampling method will give important hints on the brake's potential for improvement.

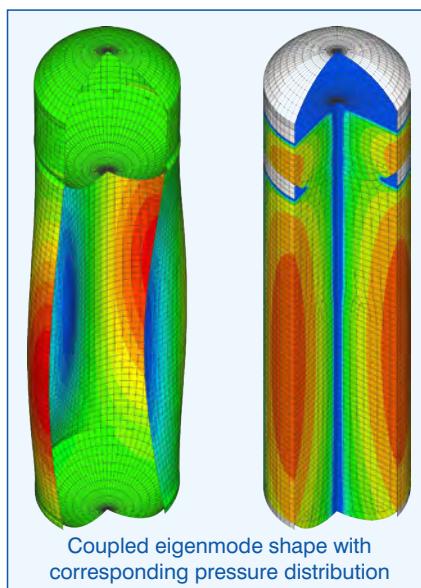
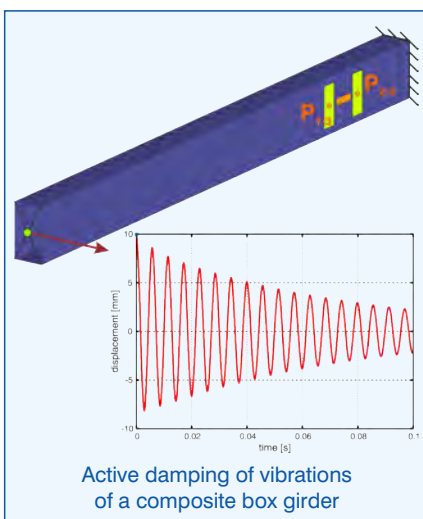

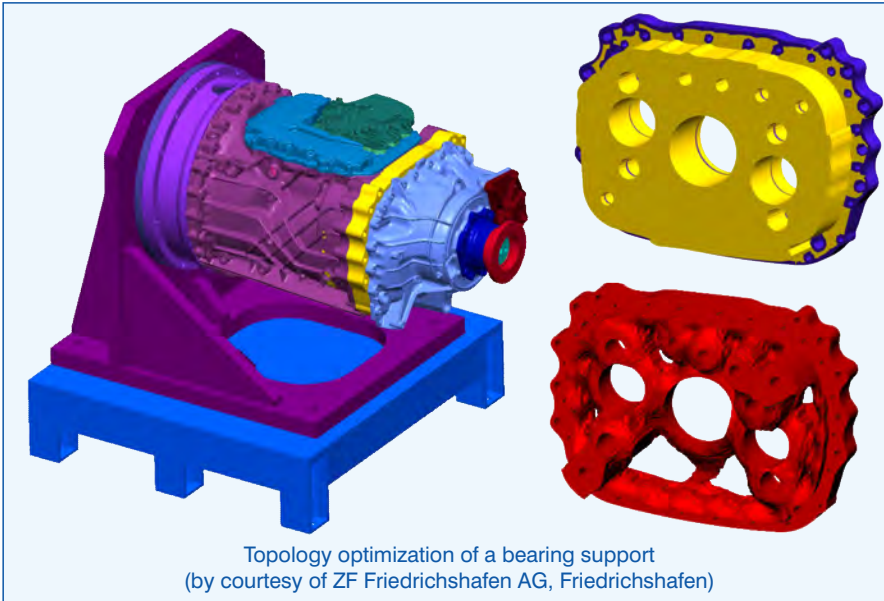

A parametric **shape optimization** is performed by several methods like position optimization, bead generation, or shape optimization using shape basis vectors.

The **position optimization** can be characterized by a change of the position of two or more parts to each other or by a change of the position of boundary conditions in order to fulfil certain conditions like minimum deformations.

The **bead generation** is used with shell structures in order to achieve certain static or dynamic properties of the optimized parts by a suitable bead pattern.

This group of modules comprises the optimization methods like sizing optimization, topology optimization, and shape optimization. In addition, reliability analysis is available to handle uncertain model parameters. An optimization under reliability constraints is supported as robust design optimization.

To start optimization a design space exploration using **sampling** is a good first step before starting optimization. In this way different parameter settings can be used to get more information on the effect of certain parameters and the sensitivity of result quantities due to parameter changes.

Dependent on the optimization method, different analysis types can be used in optimization loops, like static analysis, contact analysis, linear buckling analysis, nonlinear material behavior, real and complex eigenvalue analysis, modal frequency response analysis, steady-state heat transfer analysis. Limits of design variables or numerous result quantities can be used as objective or side constraint.

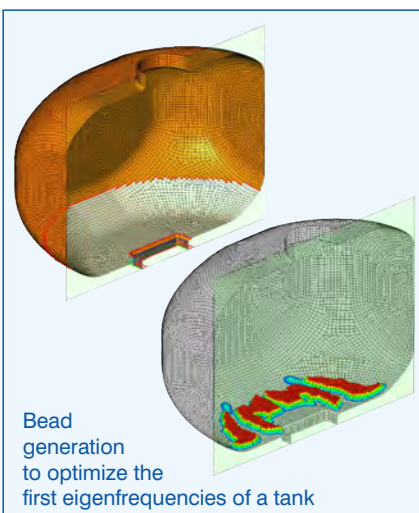
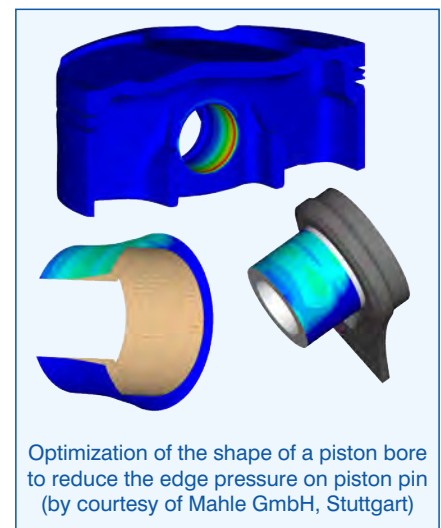



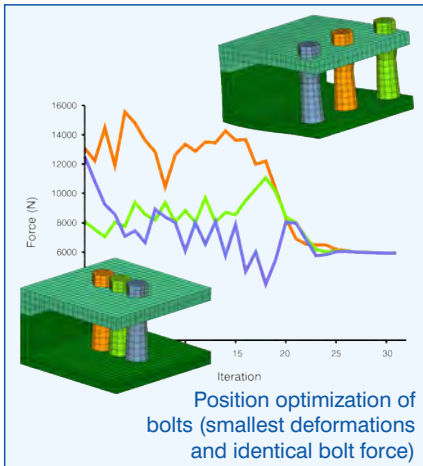

The non-parametric **freeform optimization** is mainly used to homogenize stress fields or to optimize the weight of parts under stress limits. To achieve that, material can be added or released at complex surfaces in normal direction. Additional constraints like displacements or release directions are also possible.

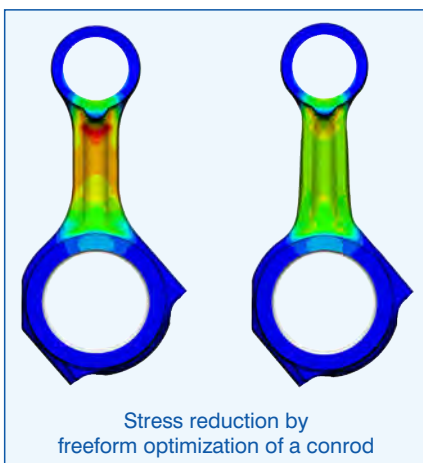

The **reliability analysis** handles uncertain model parameters and their influence on the structural behavior. For a given failure mode, it calculates the probability of failure and its sensitivities with regard to the uncertain variables.

A **sizing optimization** uses other model parameters than node coordinates as design variables like shell thicknesses, beam cross sections, material parameters, property values of spring, mass, and damper elements or even parameters of control elements.

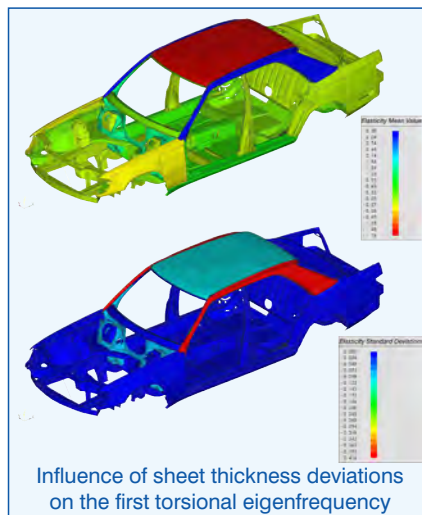

Due to the unification of optimization methods like parametric shape optimization, sizing and topology optimization, all these methods can be used simultaneously in a **Multi-Modal Optimization** to jointly solve an optimization task.

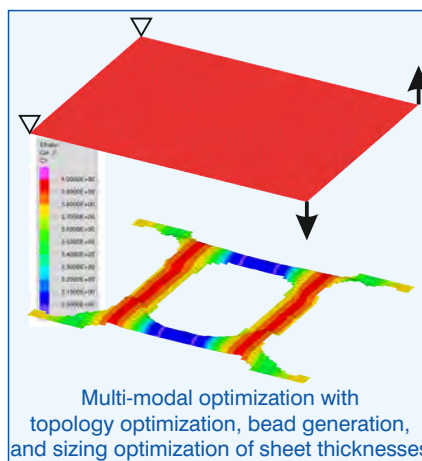

The **topology optimization** starts from a design space in order to find the optimal material distribution in this design space for a given design objective. Objective and side constraints can be defined in the design space or outside in the other parts of the structure. In addition, manufacturing constraints can be specified for symmetries, release directions, minimum and maximum member sizes, and overhang angles as 3D printing condition to influence the design. The element filling ratio is used as design variable, which directly influences stiffness and mass of each element. After convergence, the elements in the design space are either those with filling ratio near one, which represent the desired structural behaviour, or those with filling ratio near zero, which are not needed to achieve this behaviour. After an automatic surface smoothing of the remaining structure, it can be exported as mesh or geometry (STL).

Topology optimization may also be used with other quantities like sheet thicknesses (so-called **Free Sizing**).

**Laminates** can be optimized by free sizing for new design concepts and by sizing optimization of ply thickness and angle also with ply failure constraints.



Dynamic condensation in the engine analysis using substructuring (for the calculation of sound radiation power) by courtesy of Daimler AG, Stuttgart.

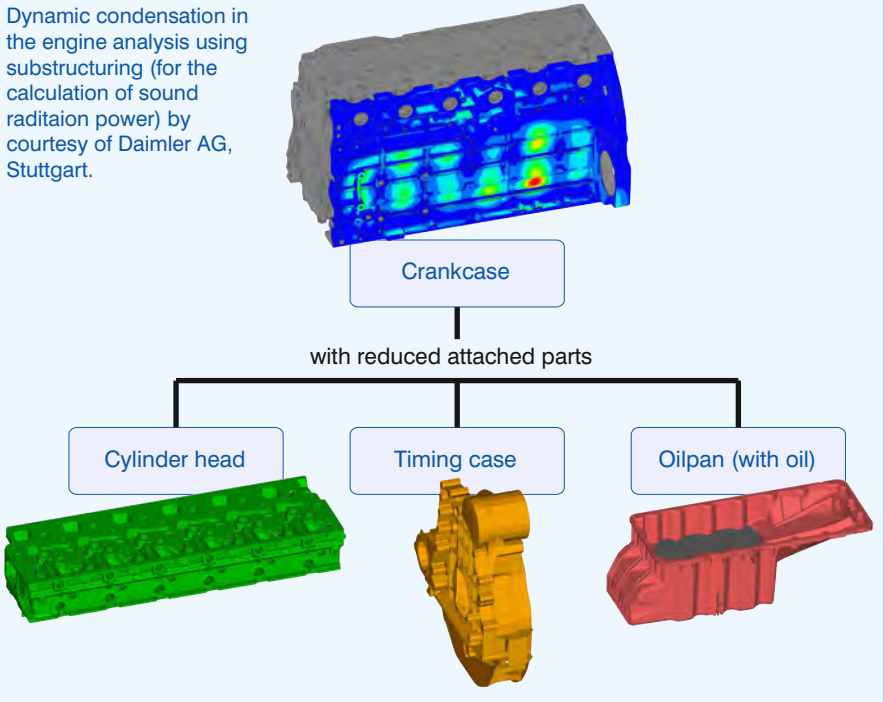

This group of modules comprises more analysis modules for electrodynamics, some special functions like laminate analysis, and an innovative new spot weld concept as well as the interfaces, which are directly supported by PERMAS to other software products.

Linear static and dynamic electrodynamic tasks can be solved with the corresponding modules. Generated heat according to the Joule effect or induced forces can be directly used in subsequent structural analysis.

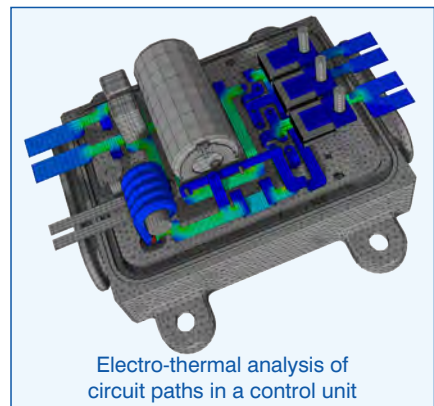

Electro-thermal analysis of circuit paths in a control unit

By **substructuring**, an FE model can be split into an arbitrary number of substructures (so-called components). The components can be assembled like single elements to get a complete structure (so-called configuration).

A configuration can be assembled by an arbitrary number of levels up to the top component (i.e. the root of the substructure tree). Each level may introduce new elements, loads, and boundary conditions.

For the reduction of components, **static and dynamic reduction** is available. By this way, matrix models can be generated, which represent the FE models of the reduced components and are suitable for model exchange between cooperation partners without exchanging the model details.



For modeling and analysis of laminated **composites**, triangular and quadrangular shell elements can be used. Their properties are described by the layer set-up or directly by ABD matrices. Ply failure criteria can be evaluated.

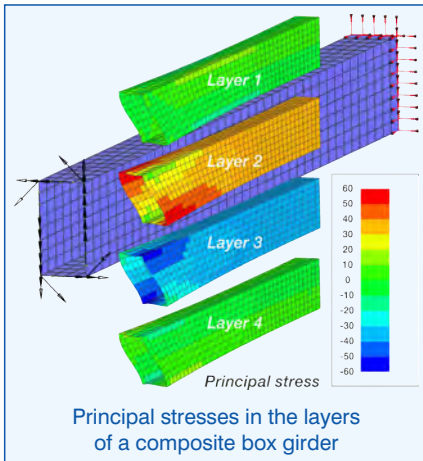

A special **spot weld element** is available, which essentially reduces the sensitivity of stress results due to the mesh size of the flanges.

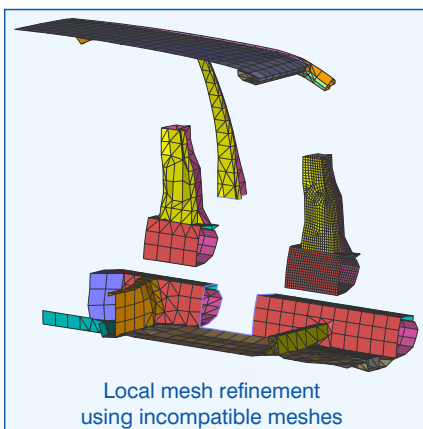

Results, which are calculated with a coarse mesh, can be applied as boundary conditions for a finer meshed part of the structure (e.g. in order to calculate more precise stresses). This **submodeling** technique also enables nonlinear analysis of parts based on linear analysis of the complete structure.

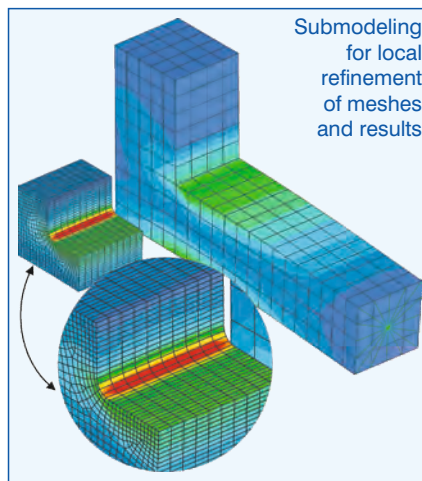

By **automated part coupling** through incompatible meshing of parts, more flexible and faster modeling is enabled, because meshes need not to be made compatible by expensive mesh adaptations and replacing parts by other meshes become much easier.

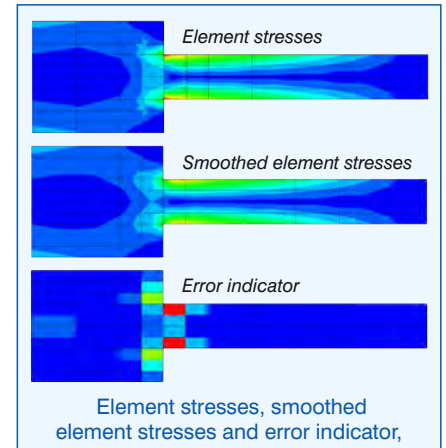

A Smooth Patch Recovery (SPR) method is applied to get **SPR stresses** beside classical stress calculation. The difference between both stresses defines an (Absolute) **Error Indicator (AEI)**, which can be used for mesh validation and further mesh refinement, if required. In addition, the stress gradient normal to the surface is calculated at the surface nodes.

<ul style="list-style-type: none"> <li>• VisPER</li> <li>• MEDINA</li> <li>• Patran</li> <li>• I-deas</li> <li>• Hypermesh, Hyperview</li> <li>• Ansa</li> <li>• SimLab</li> <li>• NX</li> </ul>	<ul style="list-style-type: none"> <li>• Adams MNF</li> <li>• AVL_EXCITE</li> <li>• Altair MotionSolve</li> <li>• VLAB Motion, Durability</li> <li>• Simpack</li> </ul>
<ul style="list-style-type: none"> <li>• Nastran BDF + OP2</li> <li>• Abaqus INP</li> </ul>	<ul style="list-style-type: none"> <li>• VAO</li> </ul>
<ul style="list-style-type: none"> <li>• ADSTEFAN</li> <li>• Magmasoft</li> </ul>	<ul style="list-style-type: none"> <li>• Femfat</li> <li>• EnSight</li> </ul>

Interfaces (blue: in PERMAS, black: external)

PERMAS is an open system and maintains numerous **interfaces** to other software products.

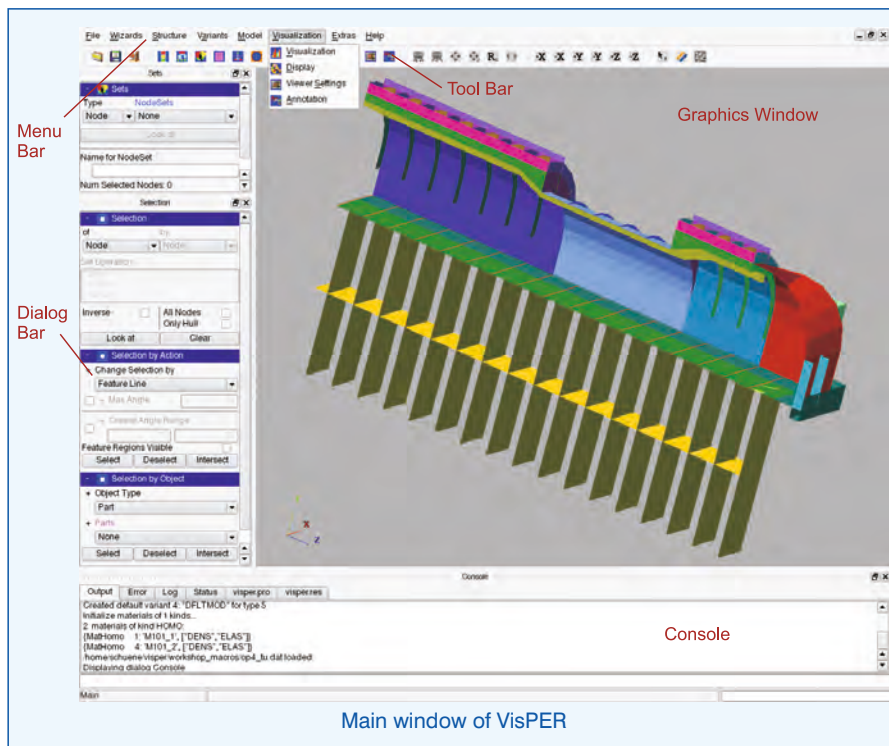

Beside the specification of element properties, MPC conditions, boundary conditions, and loads, VisPER comprises specialized **wizards**, which guide the user through the respective modeling steps:

### General

- Assembly and part exchange
- Brake squeal analysis
- Design by simulation
- Pressfit
- Sampling

### Contact

- Contact modeling
- Bolt pretension

### Optimization:

- Topology optimization
- Sizing optimization
- Shape optimization (with bead generation and position optimization)
- Freeform optimization

### Others:

- Fluid-structure coupling
- Substructuring
- Rigid body mode decoupling (RBM assistant)

VisPER is the graphical pre- and post-processor of PERMAS. It comprises the pre-processing of PERMAS models (mainly on the basis of already existing meshes) and the post-processing of PERMAS results.

In post-processing, XY plots can be generated using VisPER or 'PERMASgraph', a specialized tool for XY plots.

For the evaluation of spot weld forces, a special method is available, which uses traffic light labeling to visualize critical and non-critical values of the normal and shear forces in spot welds. The stresses can be shown in addition for a full assessment of the stresses in a flange.

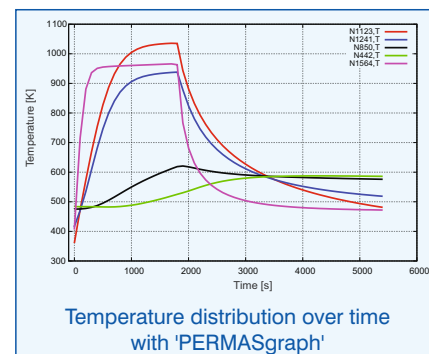
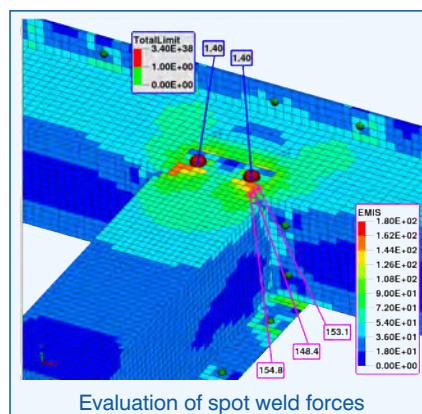



VisPER also performs the task of model verification by visualization and evaluation of numerous PERMAS verification results, like projection vectors and unconnected nodes in surface to surface MPC connections. In addition, a message dialog evaluates the PERMAS diagnostic messages and shows the affected model parts directly.

Name	S	C	W	A
BOX				
FLUID				
FLUIDIF				
HM_0001				
HM_0002				
HM_0003				
HM_0004				
HM_0005				
HM_0006				
HM_0007				
HM_0008				
HM_0009				
HM_0010				
SHELL_1				
SHELL_2				
SHELL_3				

Graphical properties of parts and element sets (S=shown, C=colored, W=wireframe, A=active)

Pre- and post-processing for a freeform optimization

VisPER has a modern interactive graphical user interface for easy and intuitive application. A simple selection of the shown model parts, working with transparency and cutting planes, the simple generation of animations, and many other useful interactions are supporting the effective and efficient working with this tool.

Comprehensive options for adjustment provide an easy customization to the user's preferred working style. Self-defined abbreviations for standard functions accelerate many operations. Macros using the programming language Python can easily be generated by recording and used later.

Topology optimization of a gear wheel with cyclic symmetry and release directions

VisPER is based on the infrastructure of PERMAS, which provides most of the interfaces in both PERMAS and VisPER in the same way, where VisPER additionally gives the direct visual feedback about the read model to the user.

In addition, results of PERMAS can be exported in other formats.

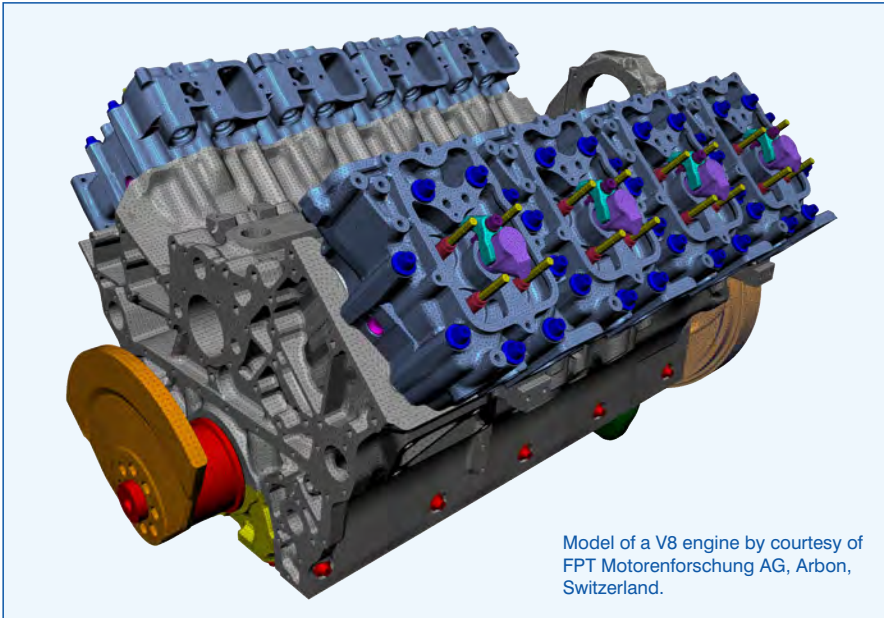

## PERMAS Modules:

### Thermo-Mechanics:

- MQA** Basic module
- LS** Linear static analysis
- CA+CAX** Contact analysis
- CAU** Contact geometry update
- CAMG** Contact multigrid solver
- NLS** Nonlinear static analysis
- NLSMAT** Extended mat. laws
- NLSA** Hyperelastic material
- BA** Linear buckling analysis
- HT** Heat transfer
- NLHT** Nonlinear heat transfer

### Vibro-Acoustics:

- DEV** Dynamics (eigenvalues)
- DEVX** Extended mode analysis
- MLDR** Eigenmodes with MLDR
- DRA** Dynamics (response)
- DRX** Extended dynamics
- FS** Fluid-structure acoustics
- NLD** Nonlinear dynamics

### Optimal Design:

- OPT** Design optimization
- TOPO** Layout optimization
- AOS** Advanced optim. solvers
- RA** Reliability analysis

### Other functions:

- EMS** Electro-/magneto-statics
- EMD** Electrodynamics
- LA** Laminat analysis
- WLDS** Refined weldspot model
- GINR** Generalized inertia relief
- XPU** GPU accelerator

### Interfaces:

- MEDI** MEDINA door
- PAT** PATRAN door
- ID** I-DEAS door
- AD** ADAMS interface
- EXCI** EXCITE interface
- SIM** SimPack interface
- HMS** MotionSolve interface
- H3D** HYPERVIEW interface
- VLAB** Virtual.Lab interface
- ADS** ADSTEFAN interface
- MAT** MATLAB interface
- NAS** NASTRAN door
- ABA** ABAQUS door

## VisPER Modules:

- VBAS** Basic module
- VCA** Contact modeling
- VOPT** Optimization models
- VTOP** Topology optimization
- VFS** Fluid modeling

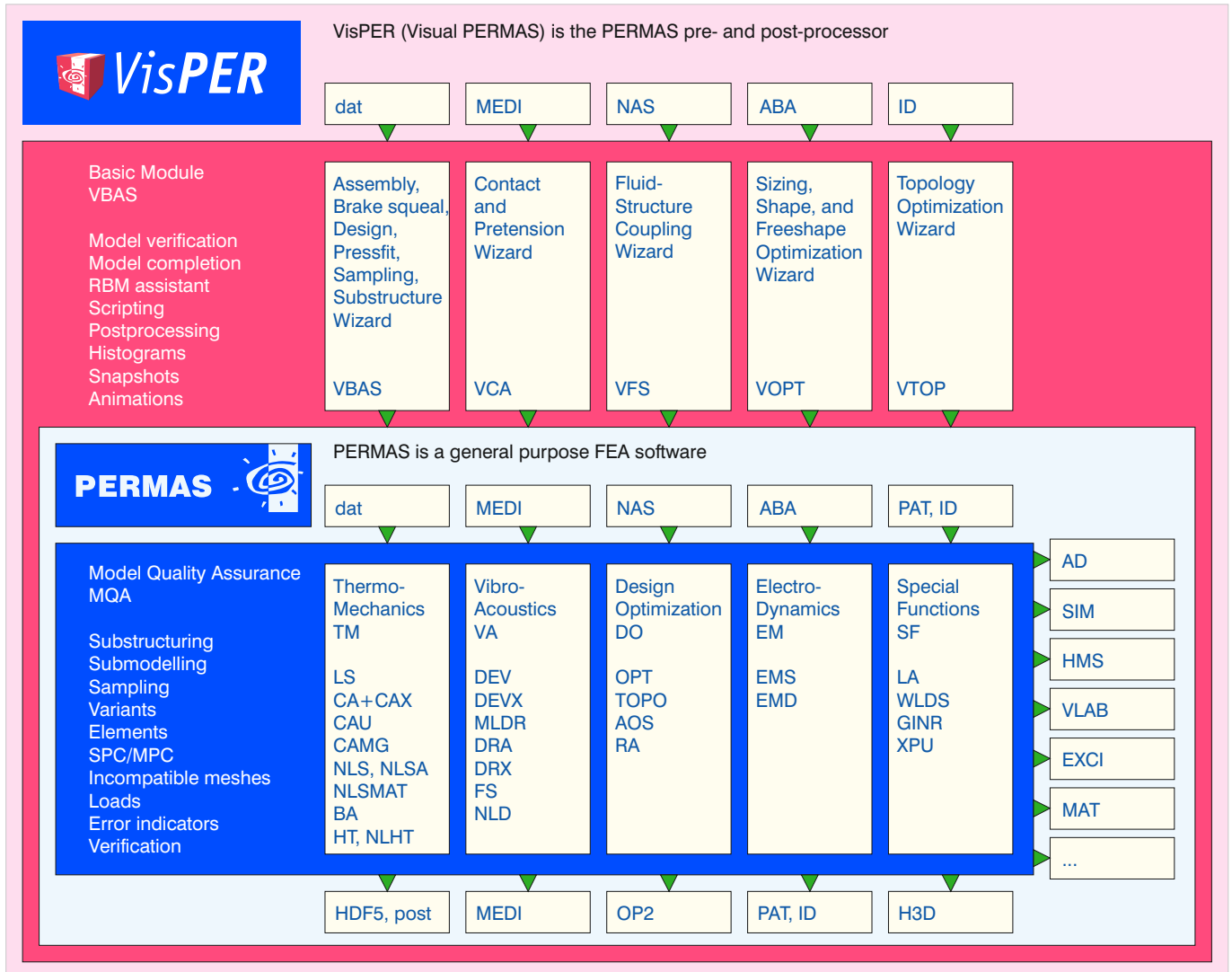

VisPER comprises PERMAS and uses the same data basis. So, a perfect data compatibility exists between pre-processing, analysis, and post-processing.

HPC (High Performance Computing) through parallelization (multi-threading), the additional use of a GPU (like Nvidia Tesla Kepler GPU) and special algorithms (like contact, MLDR, fluid-structure-coupling).

Detailed information about the different modules can be found in the PERMAS Product Description on [www.intes.de](http://www.intes.de) --> Company --> Publications

INTES GmbH  
Breitwiesenstr. 28  
70565 Stuttgart, Germany  
Tel.: +49-711-784990  
Fax: +49-711-7849910  
E-mail: [info@intes.de](mailto:info@intes.de)  
Web: [www.intes.de](http://www.intes.de)

Copyright 2020 INTES GmbH,  
Stuttgart, all rights reserved.

*The finite element model of a  
power cutter for dynamic  
analyses on the frontpage  
appears by courtesy of  
ANDREAS STIHL AG & Co. KG  
in Waiblingen, Germany.*

*If not specified differently, all  
registered names and  
trademarks are legally protected  
brands of INTES or other  
organizations. The registered  
trademarks of INTES are  
PERMAS and VisPER. The use  
of other product names does  
not imply that these names are  
not protected. They are used  
here only to inform the reader.*